

# GSCAN

The background of the slide is a photograph of the Golden Gate Bridge in San Francisco, viewed from a high angle looking down the length of the bridge towards the water. The bridge's iconic orange-red color is prominent. The sky is a clear, pale blue. The water is a deep, vibrant blue. The overall aesthetic is clean and professional. The GSCAN logo is rendered in a large, white, bold, sans-serif font at the top. Below the title, the main text is in a white, sans-serif font. A white plus sign is positioned to the right of the main text. At the bottom, there are two white horizontal lines, one on the left and one on the right, framing the text.

Muon Tomography solutions by GScan:  
From bridges to nuclear system

Presented by Andi Hektor (Co-founder & CSO)

On behalf of Madis Kiisk (Co-founder & R&D lead), Märt Mägi  
(Co-founder & CTO), and GScan's R&D team

ELI Workshop, Mar 2025

# GScan

Non-Destructive Testing & Structural Health Monitoring

Team: 40 employees + 25 collaborators in joint projects

Located in the Estonia, UK, and Germany

Biz domains:

- NDT for critical structures in the built world
- Nuclear decommissioning and waste classification
- NDT for large composite objects:
  - Energy and O&G systems
  - Defence
  - Naval

Investments: €13mln grants + €4mln private investments



# GScan

## Partner network

Uni. of Tartu (Estonia), €1.2m+

CAEN (Italy), €1m

DLR (German aerospace agency), €0.8m

Foundation Bruno Kessler (Italy), €0.8m

Imperial College London (UK), €0.5m

UCLouvain (Belgium), €0.5m

Uni. of Cambridge (UK), €0.42m

Uni. of Sheffield (UK), €0.4m

**DESY (Germany), €0.3m**

University of Cambridge (UK), €0.3m

KBFI/NICBP (Estonia), €0.2m

European Space Agency (ESA), €0.3m

CERN (Switzerland), €0.07m

Uni. of Tokyo (Japan), Uni. of Exeter (UK), Taltech (Estonia)

## Recognized business partners

**Jacobs**



**SGS**

**AtkinsRéalis**



**Sellafield Ltd**

**ALARA**  
As Low As Reasonably Achievable

 REPUBLIC OF ESTONIA  
TRANSPORT ADMINISTRATION

# Our motivation: Built Environment Not Properly Managed

Majority of decision about assets (demolish, limit usage, defining reconstruction scope) are made **based on conservative assessments and not clear facts**



50% of built infrastructure is >50 yrs old

- = 2 mln bridges
- <13% in good condition
- 50k bridges/year reach their lifespan



75% of 2050 the infrastructure not yet built



- 3 tons of concrete used / year / every human
- 8% of global Co2



No good tools & methods to see inside

- >40cm of inhomogeneous materials (like reinforced concrete or timber)
- see inside shielded materials

4x

Investment overspend

2x

Deficient maintenance

5x

Excessive CO2 emissions

# Client requirements

## Non-Destructive Testing

- Imaging resolution sufficient for rebar and tendon ducts – **a few millimeter spatial resolution**
- Discrimination of corrosion and chemical changes, e.g., carbonisation – **automated material classification**
- **Reasonable cost**

# Our approach

- Develop hardware with tracking performance and operational requirements that meet the requirements of these applications
- Deploy scattering and transmission based imaging and material classification.
- Our approach is to solve first the inverse problem, detect objects and its boundaries and classify material of each object



—

# GScan's scanner / tracker technology

—

# Design requirements and decisions

- Tracking accuracy - 1 mrad
- Spatial resolution - 100  $\mu\text{m}$
- Field-work requirement – robust, user friendly, compact lightweight
- Our selection - fibre mats out of plastic scintillation fibres

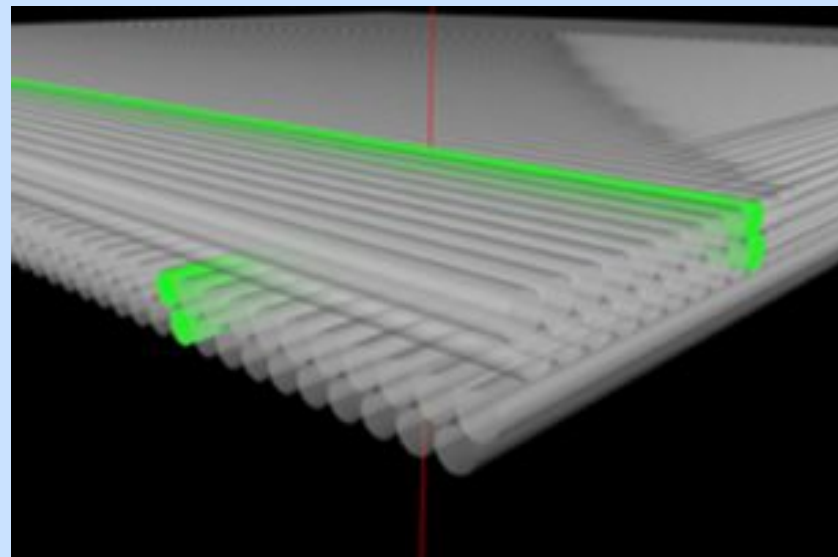
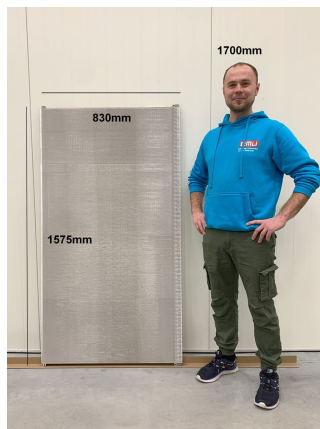

The layout of two double-layered fiber-mats, assembled orthogonally to form a x-y detection plane.

# The tracker

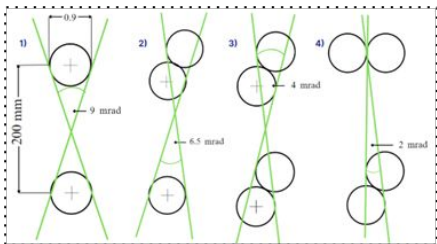

Possible combinations of the fibres/clusters hit by the passing particles.

Langemisnurga lahutusvõime langemisnurga sõltuvusest xz projektsioonis

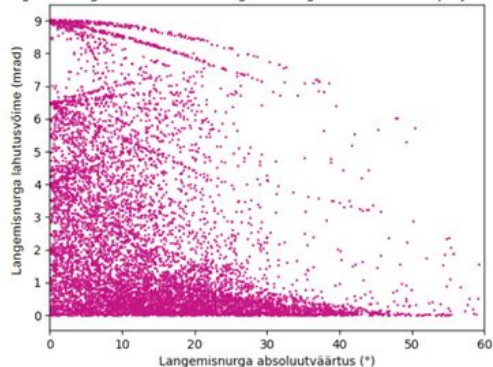

Tracking resolution as a function of the inclination angle of the particles, expressed in full width of the cone visualized above.



An image of a three-detector plane tracker, an assembly of 6 fibre-mats.



# Front-end readout

SiPM array readout is performed in two ways:

1. Via multiplexer - DAQ channel reduction 16X
2. Customised, home-made DAQ direct readout with strict-budget design condition

Below an illustration of the multiplexer schematics:

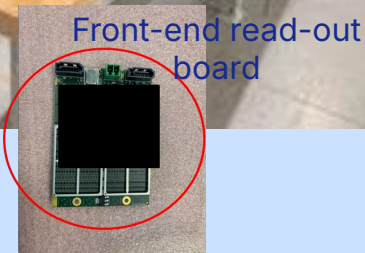
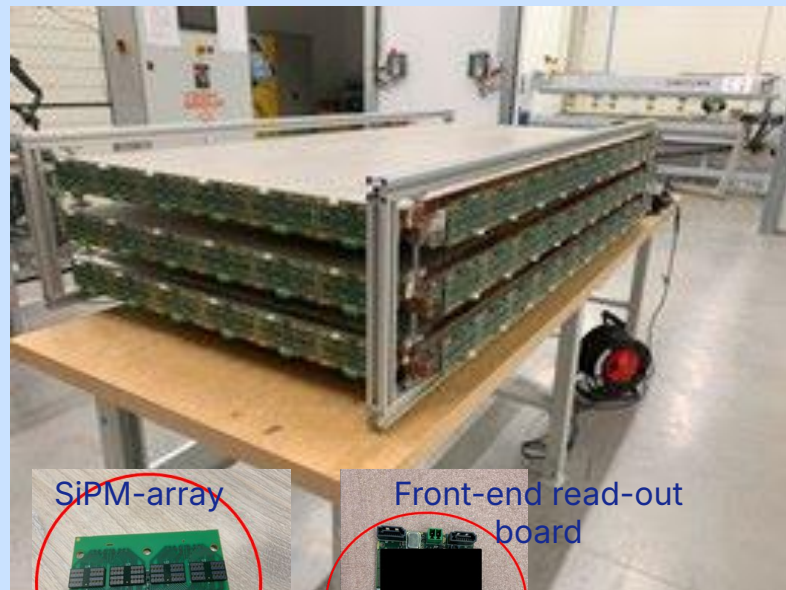
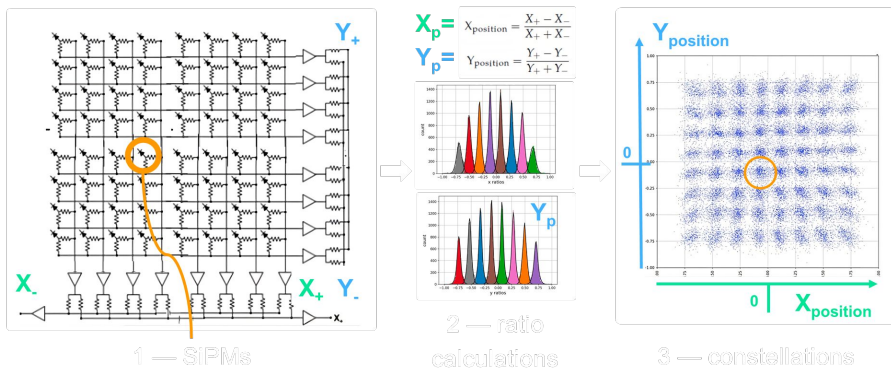

An image of a three-detector plane tracker, an assembly of 6 fibre-mats.

# muonFLUX™ Infra & Nuclear



The muonFLUX Infra system in the in-field configuration measuring critical structures of an office building (Feb 2024)



The muonFLUX Infra system in-field configuration allows to rapid and mobile transit and set up at a measurement site

# Deployment examples



Bridge element (UK)



Wind turbine towers



Scanning of a pillar

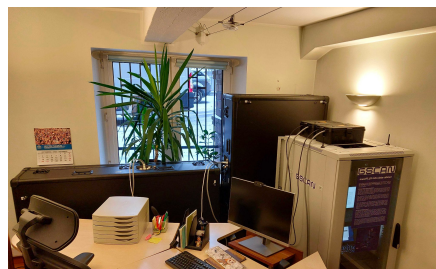

Scanning of an office wall

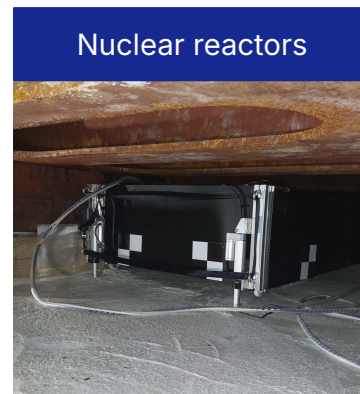

Nuclear reactors

---

---

# Data processing:

acquisition data, reconstruction, object and material recognition

---

---

# Hardware fibre clustering + particle tracking

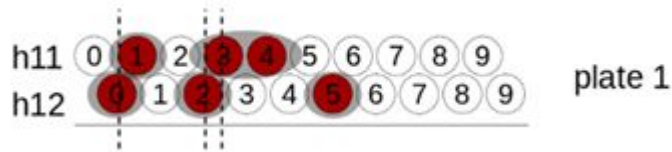

An illustration of the clustering logic. Lit fibres next to each other compose individual cluster. A fibre-mat may contain multiple clusters.

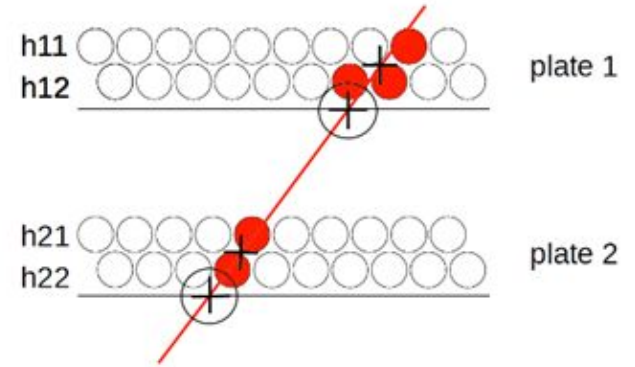

An illustration of the hit coordinate localisation in case of clusters with two- and three-fibre lit at separated x-plane and on an virtual x-y plane.

# Hardware alignment

Our approach:

- Custom Unsupervised Physics Informed Neural Network
- Develop a custom model architecture that can learn physical build.
- Use the physical properties of muons behaviour to make corrections.

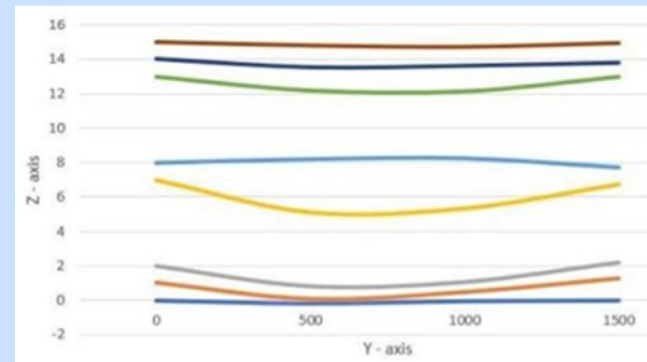
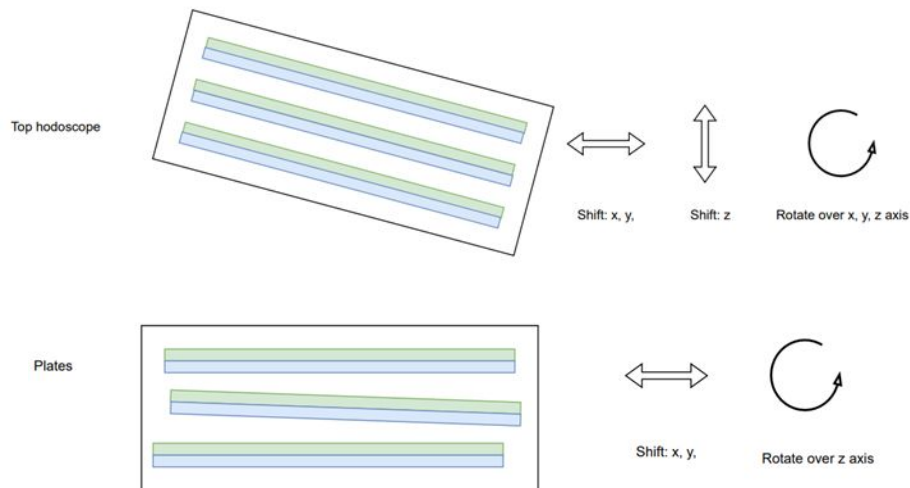

Learned curvature of a fiber mat

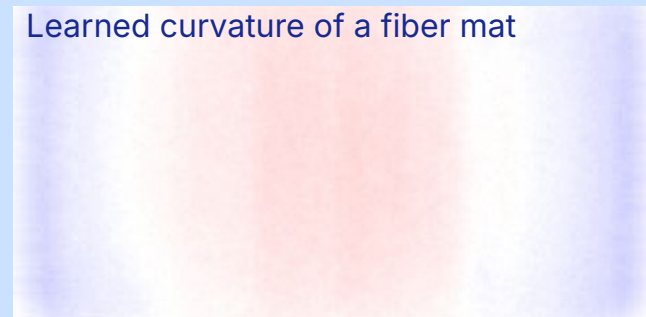

# 3D image reconstruction

## Our approach:

- Started off with ray casting and proprietary iterative algorithm
- Increased the ML expertise within the company and through the collaboration with partner research institutions to switch over fully to ML-methods
- Work in progress on development of deep-learning methods
- Integration of physics informed neural networks

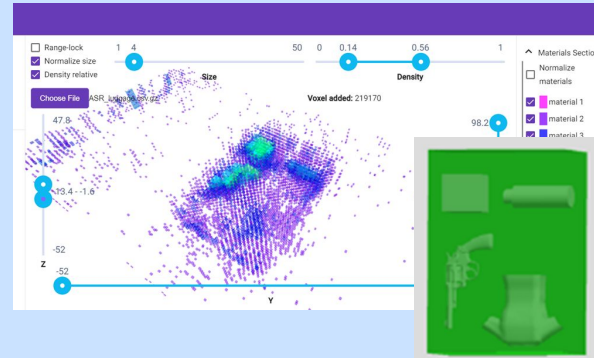

Reconstruction of 15 minute simulation of 10cm cube of RDX, 250ml bottle of water, revolver, clothes.

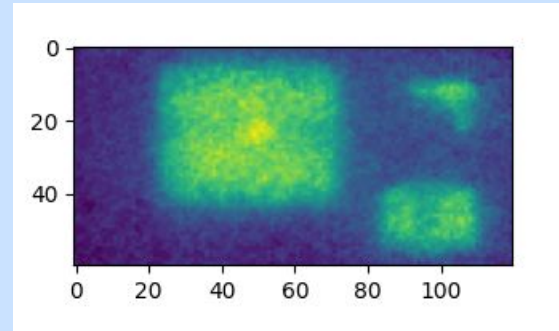

Real 15 minute measurement projection on vertical axis. Banana box, 1kg of salt inside it imitating cocaine, on right airsoft gun and below it bag containing two 1 kg sugar bags

# Object detection

- Started off with conventional and proprietary edge detection methods.
- 3D-UNET volumetric segmentation
- We utilize deep convolutional neural networks to detect objects within the volume of interest. Once the areas of attention are identified, we further enhance the information in these regions.
- Finally, a supervised classification neural network predicts the material types within the focused areas.

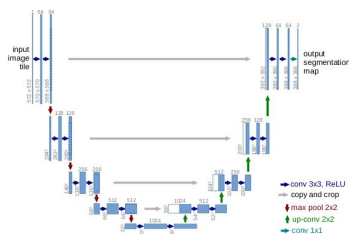
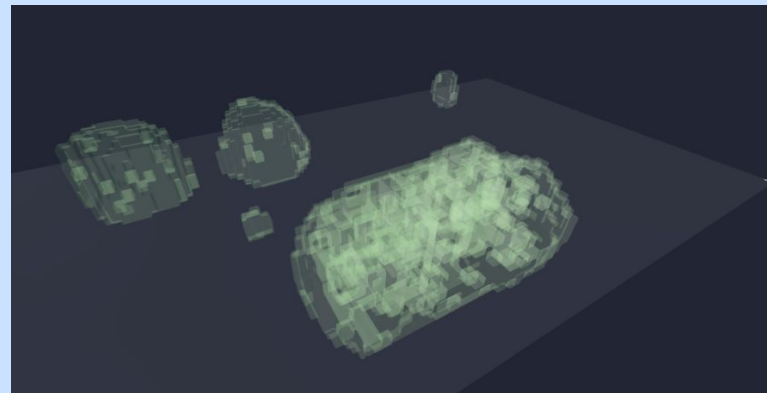

Fig. 1. U-net architecture (example for 32x32 pixels in the lowest resolution). Each blue box corresponds to a multi-channel feature map. The number of channels is denoted on top of the box. The x-y-size is provided at the lower left edge of the box. White boxes represent copied feature maps. The arrows denote the different operations.



Object detection result. 3 bags with clothes containing various small 1x1 cm objects and two 3x3cm objects randomly placed objects in scanner.



# Material classification

- Feature based classification approach - derived from using model developed NN
- Work in progress, as an example from exercise in summer 2024:
  - material classification performance 70%,
  - 20 materials in the library
  - 15 minutes scanning time
  - Objects varied in size between about 50 grams up to few kg.

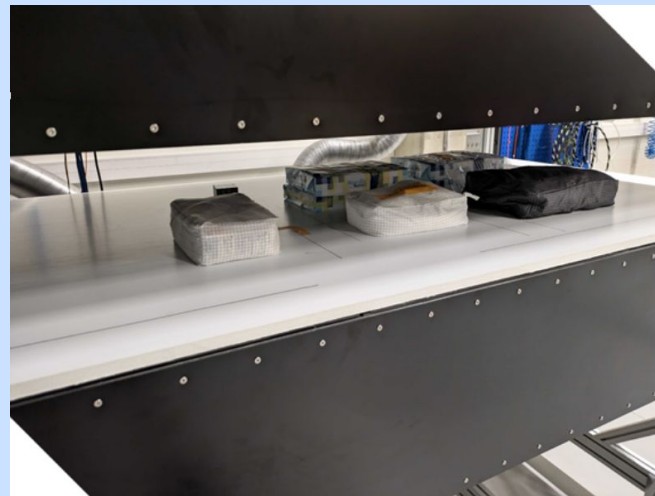

# Overview of system architecture

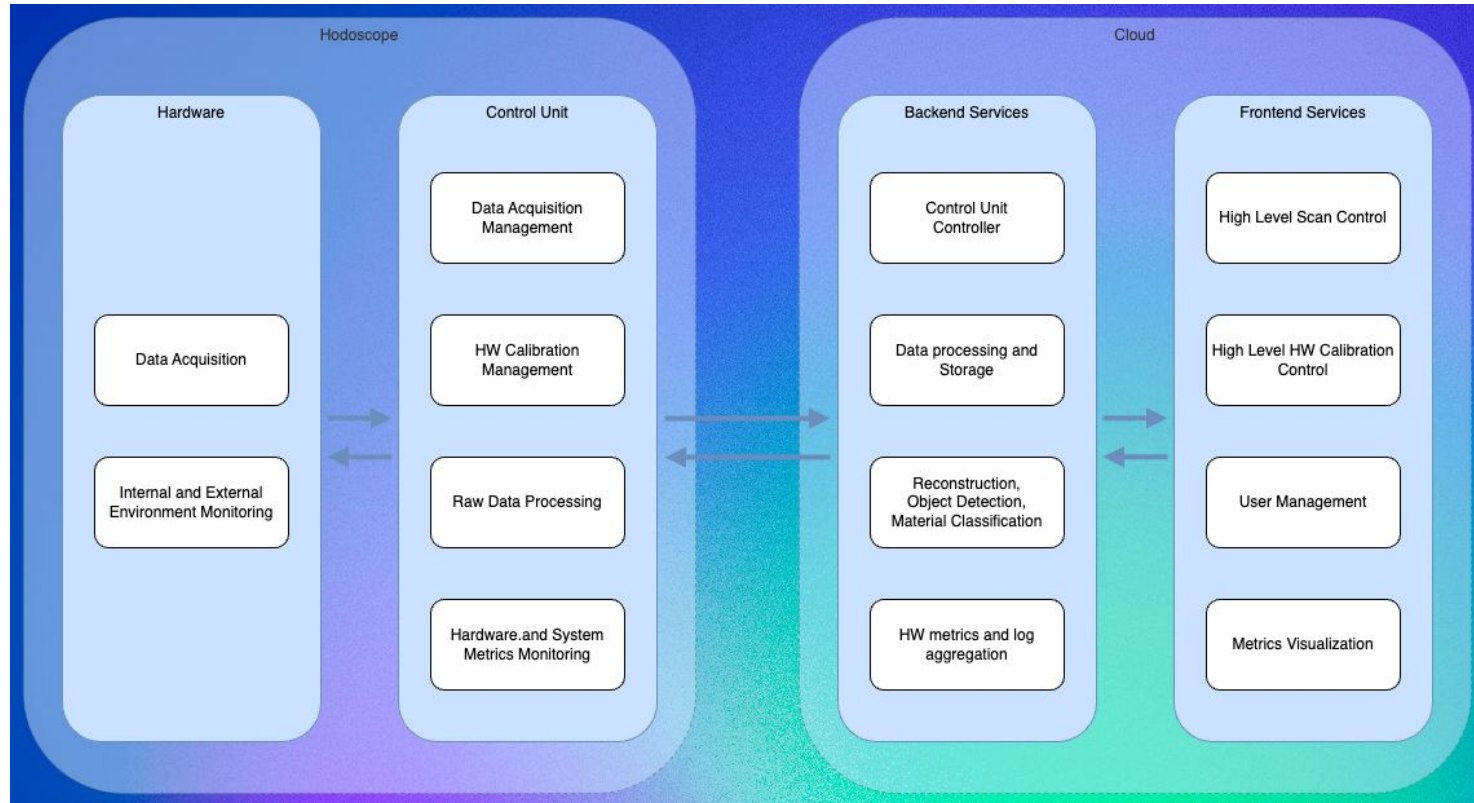

# Data and process flow

Inout from hardware



Particles' track data, apply limits and filters

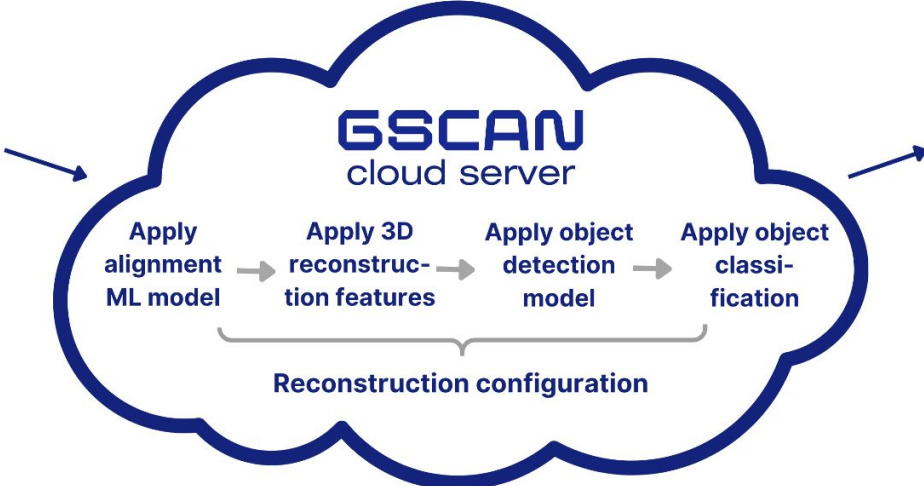

Output: 4D array to visualization flow

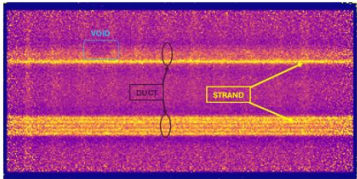

1. Defect detection
2. Identification and condition of the materials



# Example 1: Post-tensioned structures

# First potential use case: Post-tensioned systems

GScan muFLUX™  
Bridge scan



- Moonshot stage I completed 03.2024
- MS final trial with UK National Highways Q4 2024

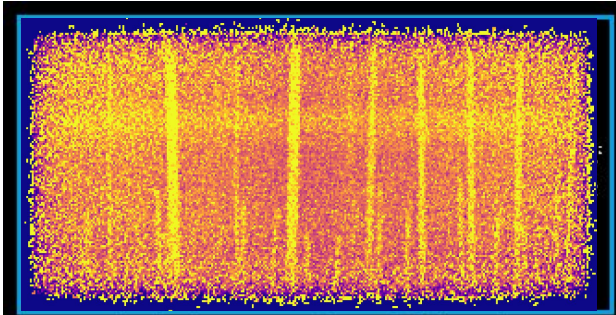

Longitudinal and transverse rebars with different diameter

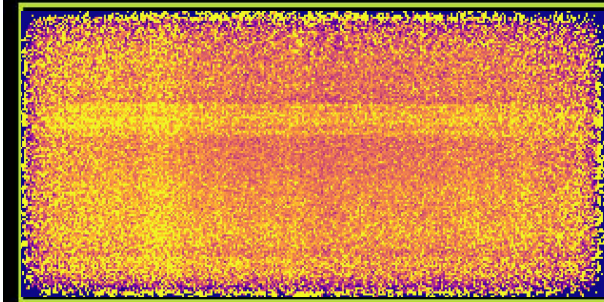

Post-tensioning duct and internal strands (lighter lines)

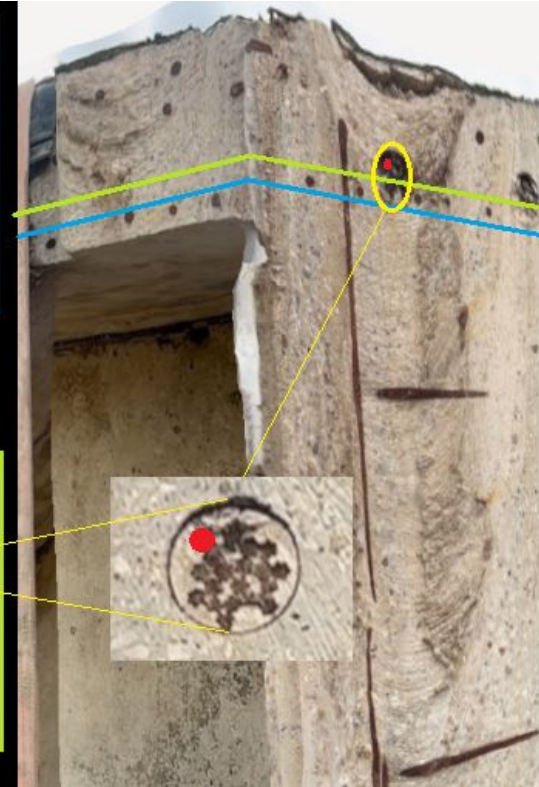

# Determining the capability with Sample measurement

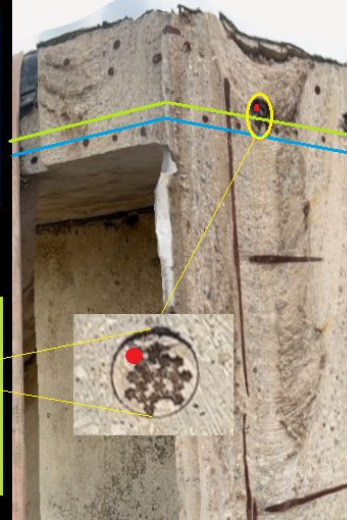
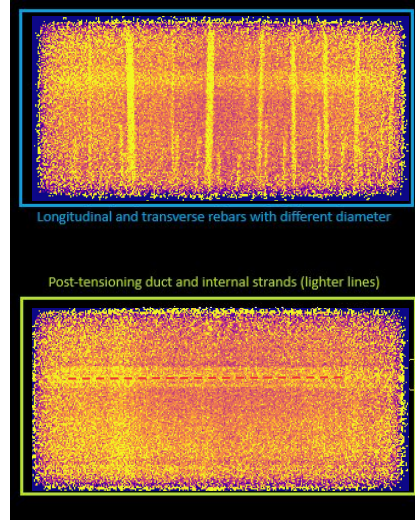

ML application

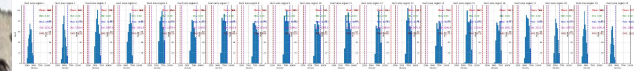

# Variety of post-tensioned systems

Design drawing

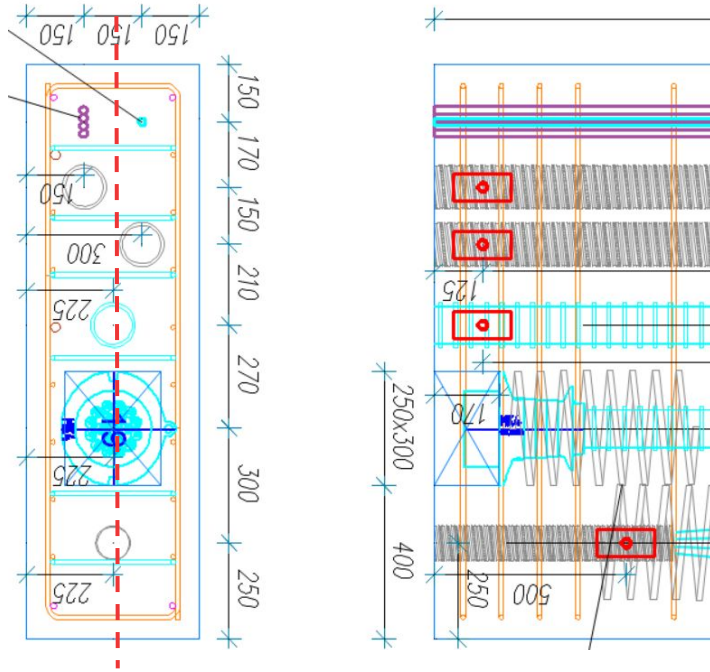

Raw reconstructions 100 h

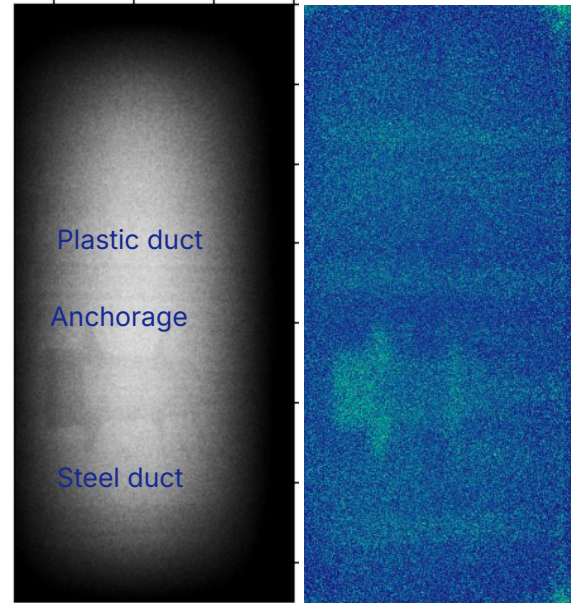

Pre casting point cloud

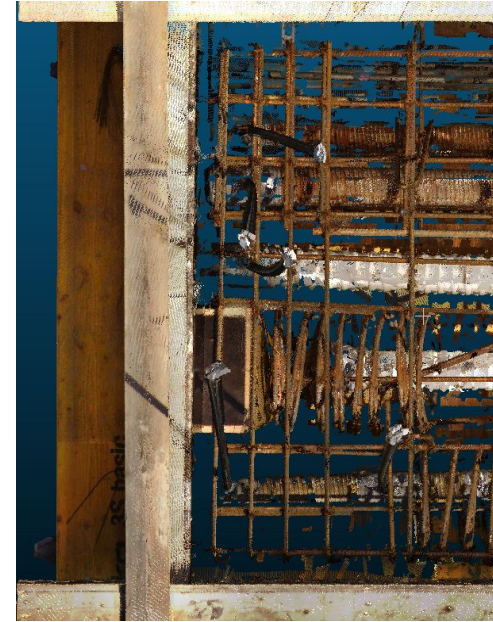

# Results: Moonshot Phase 2

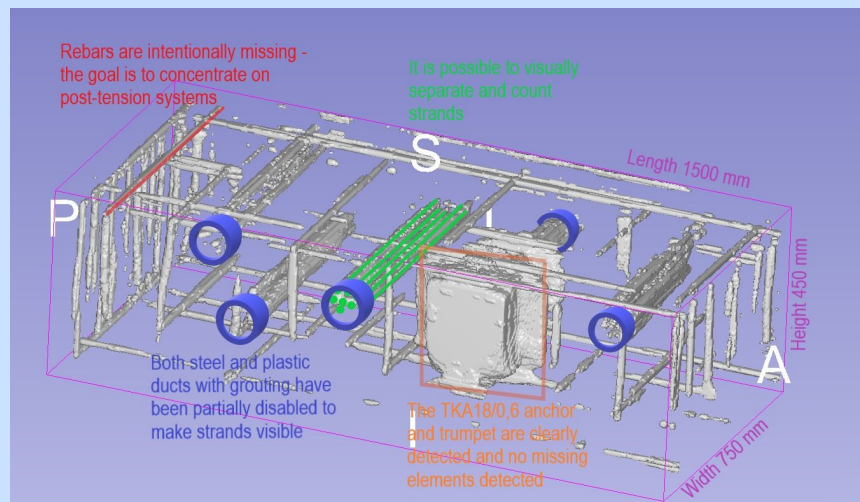
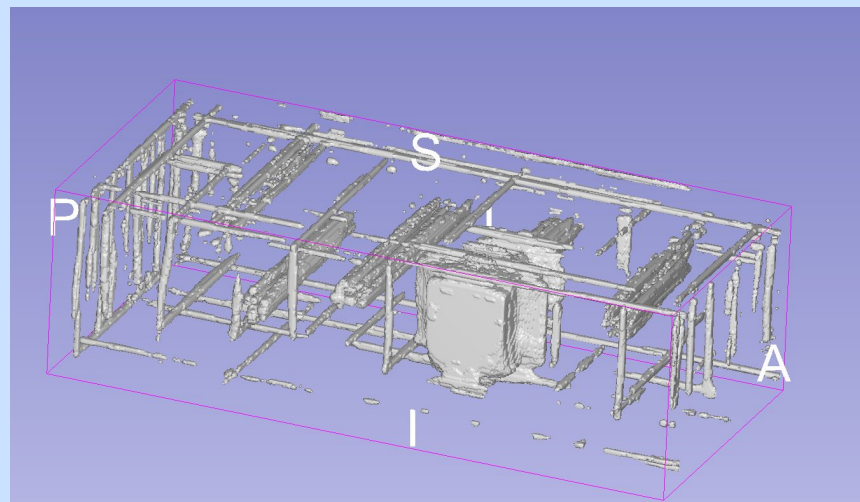
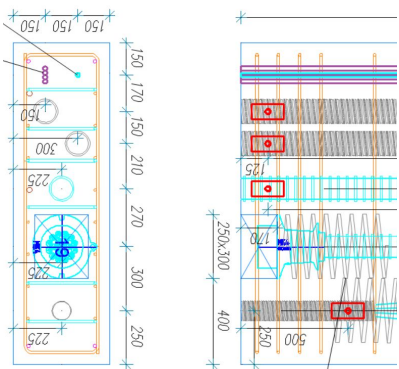



Rebars are intentionally missing -  
the goal is to concentrate on  
post-tension systems

It is possible to visually  
separate and count  
strands

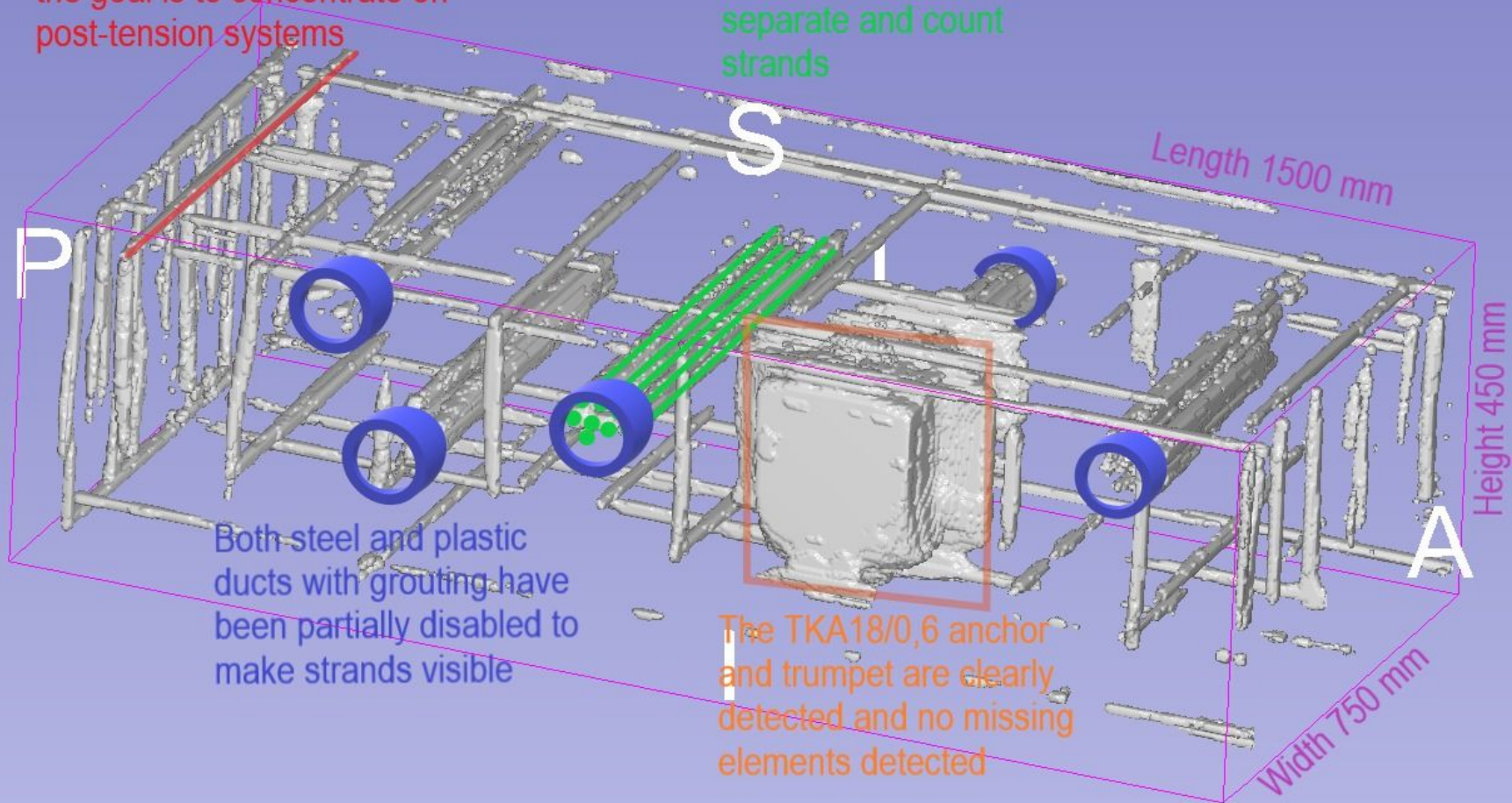

Both steel and plastic  
ducts with grouting have  
been partially disabled to  
make strands visible

The TKA18/0,6 anchor  
and trumpet are clearly  
detected and no missing  
elements detected

---

---

Example 2:  
3D imaging of nuclear submarine  
sections for decommissioning

---

---

# Use Case #1: The imaging of military nuclear reactors

## Two abandoned submarine reactors

A Soviet time training centre for sub-mariners at Paldiski, Estonia. The two reactors: 346A and 346B

No good documentation about construction, conservation, and radioactive waste dumped into the reactor sections and filled with concrete

## Time is ticking

The sections have to be decommissioned by 2040

## The main objectives:

- (1) a more exact 3D model for decommissioning
- (2) foreign objects (dumped radioactive waste)

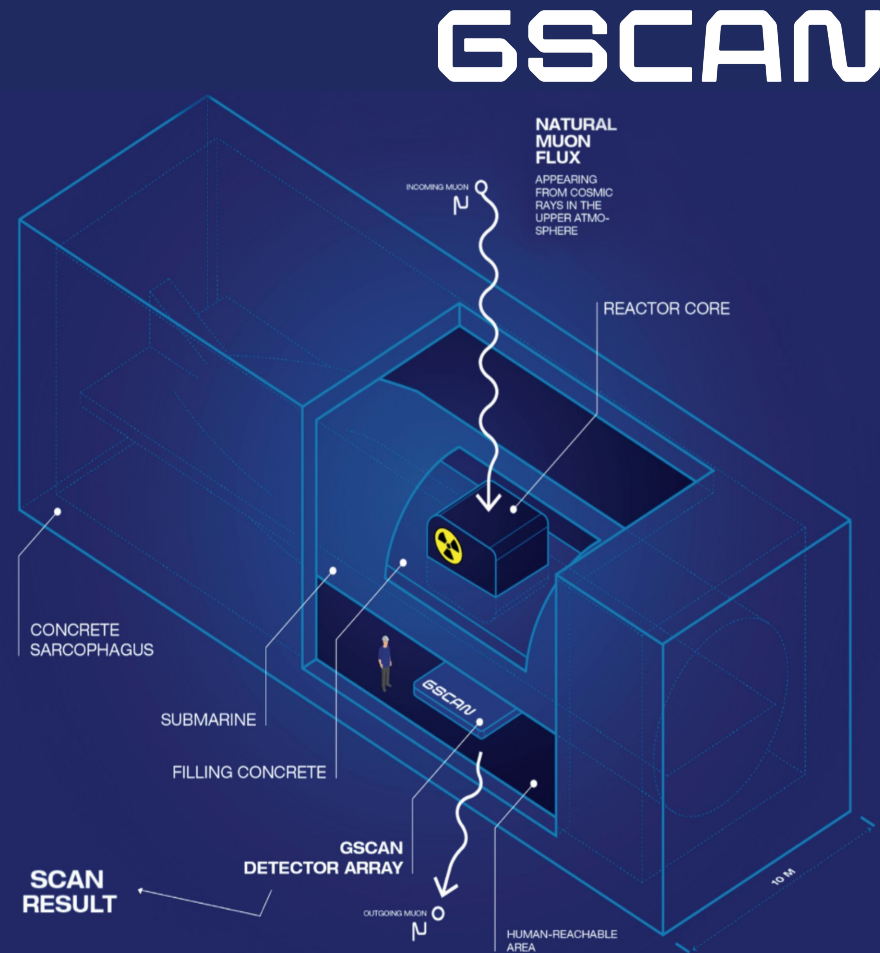

# Field work, methodology

- **Data acquisition:**

- 346A - 55 measurement locations
- 346B - 31 measurement locations
- Campaign period - 3<sup>rd</sup> of May until Sept. 22<sup>nd</sup>
- Combining 346A+346B ~4100h effective measurement time

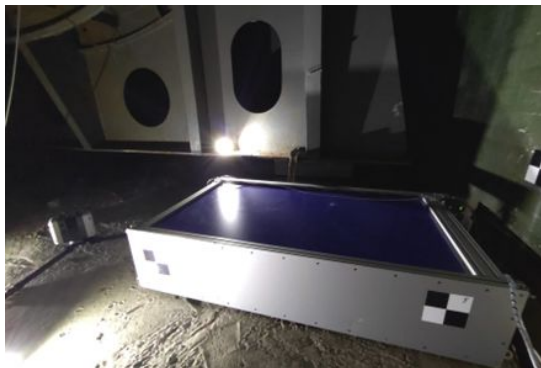

- **Imaging:**

- Formation of LIDAR coordinates based meta data and transformation single position muon trajectories into a united coordinates transformation
- Final selection - 1 cm voxel in order to ensure best image resolution
- The volume of interrogation: 346A - 15×9×10m<sup>3</sup> and 346B - 10×9,5×10m<sup>3</sup>.

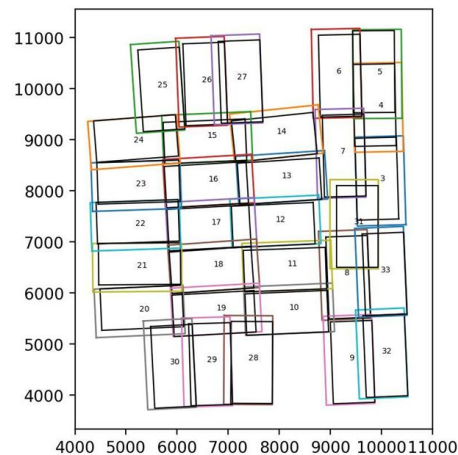

# 346B results

**In the construction part, there are significant differences compared to the existing technical data:**

- Reactor room rotated
- Placement of steam generators
- Internal biological barrier with lead lining
- Many other discrepancies with existing technical data

[ALARA\\_346B\\_z-plane  
slices\\_1cm\\_voxel\\_size.2.avi -  
Google Drive](#)

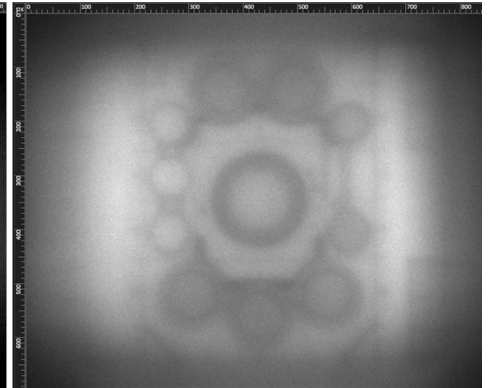
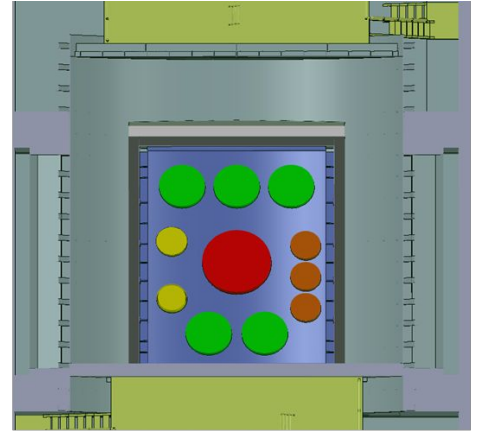

# 346B results

## Provided:

- Updated existing 3D models with the findings and
- Foreign objects (marked as green objects on top right image)

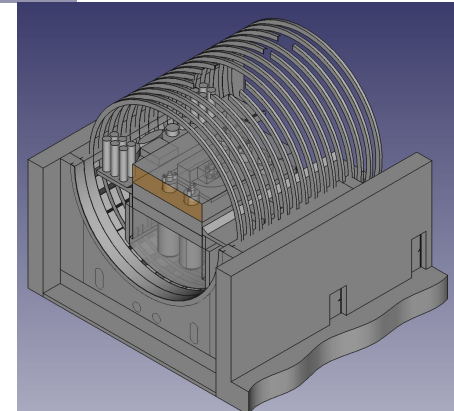
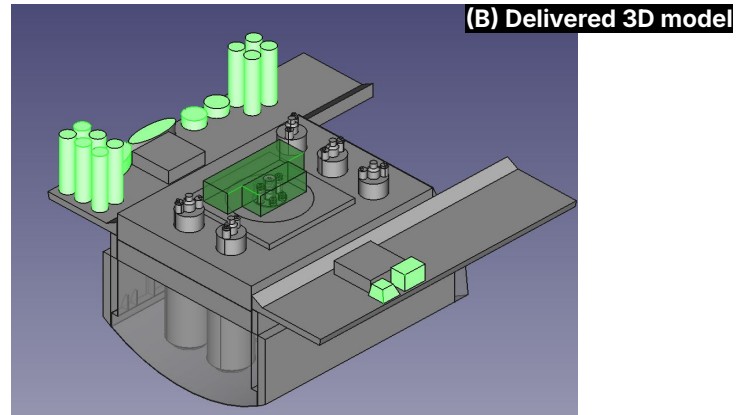
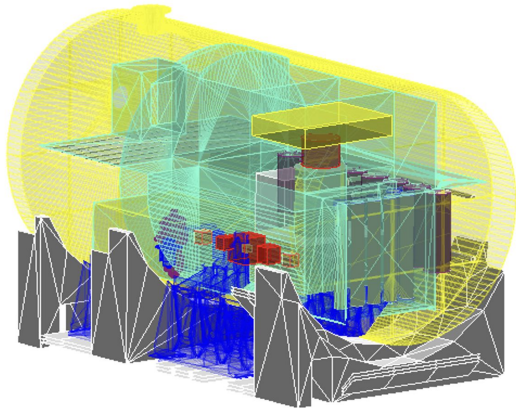

---

---

# Example 3: Security & Customs applications

---

---

# Data analysis with the User Interface: Turning the scattering and absorption data to classifying materials

Image of objects to be scanned



Reconstructed images of objects



ML based objects and material classification

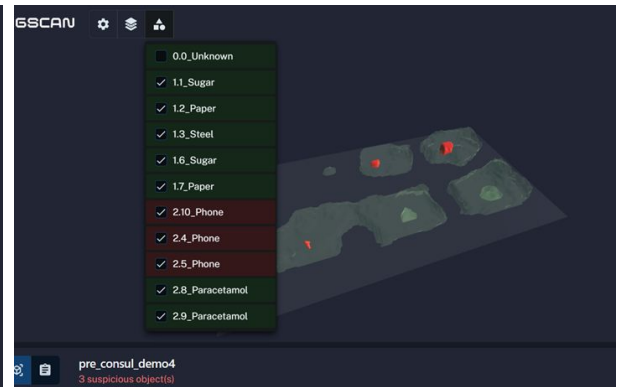
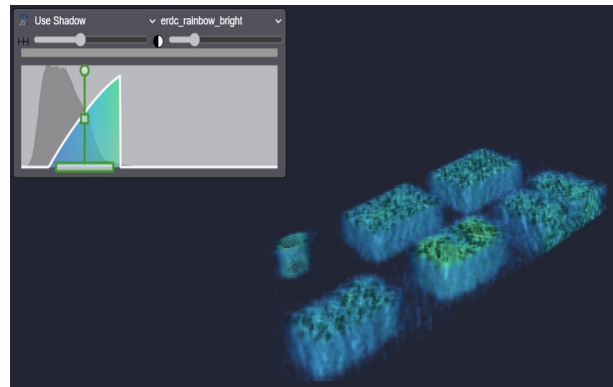
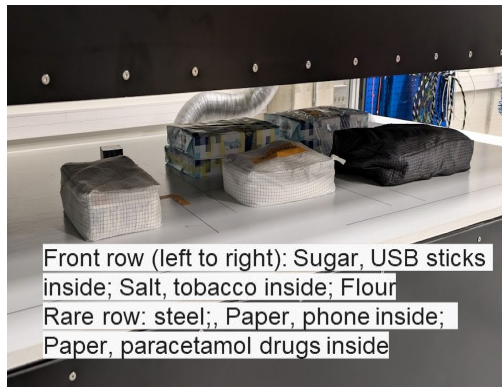

Comment: SilentBorder project technology demonstration day test done in June 2024

**Exposure time 15 min, objects in objects scenario**, mainly carbon based substances, contraband mode

Project homepage: <https://silentborder.eu/>



# Silent Border

2021 — 2025



**The world's first modular ART-system for measuring containers and vehicles** to be used by customs agencies from Estonia, Finland, Spain

*Currently producing the custom hardware*

# COSMOPORT

2023 — 2026



**The world's first mobile ART-system (TRL7) for measuring parcels and letters** to be used by customs agencies from 5 different countries.

*Currently designing the custom hardware*



# Beyond cosmic ray muons: Artificial muon sources

# Artificial muon source: why?

- To produce muons one needs 1GeV+ accelerator source of primaries, e.g. 100m linear accelerator in the case of electrons
- Laser Plasma Accelerator (LPA):  
**the game changer in the case of muon tomography!**
- Our dream: **a sea container size muon source**
- DESY: Kristjan Poder et al
- Other groups: Berkeley Lab

Measurement of directional muon beams generated at the Berkeley Lab Laser Accelerator

Davide Terzani,<sup>1,\*</sup> Stanimir Kisiov,<sup>1</sup> Stephen Greenberg,<sup>1,2</sup> Luc Le Pottier,<sup>1,2</sup> Maria Mironova,<sup>1</sup> Alex Picksley,<sup>1</sup> Joshua Stackhouse,<sup>1,3</sup> Hai-En Tsai,<sup>1</sup> Raymond Li,<sup>1,3</sup> Ela Rockafellow,<sup>4</sup> Timon Heim,<sup>1</sup> Maurice Garcia-Sciveres,<sup>1</sup> Carlo Benedetti,<sup>1</sup> John Valentine,<sup>1</sup> Howard Milchberg,<sup>4</sup> Kei Nakamura,<sup>1</sup> Anthony J. Gonsalves,<sup>1</sup> Jeroen van Tilborg,<sup>1</sup> Carl B. Schroeder,<sup>1,3</sup> Eric Esarey,<sup>1</sup> and Cameron G. R. Geddes<sup>1</sup>

<https://arxiv.org/abs/2411.02321>

# Artificial muon source: how?

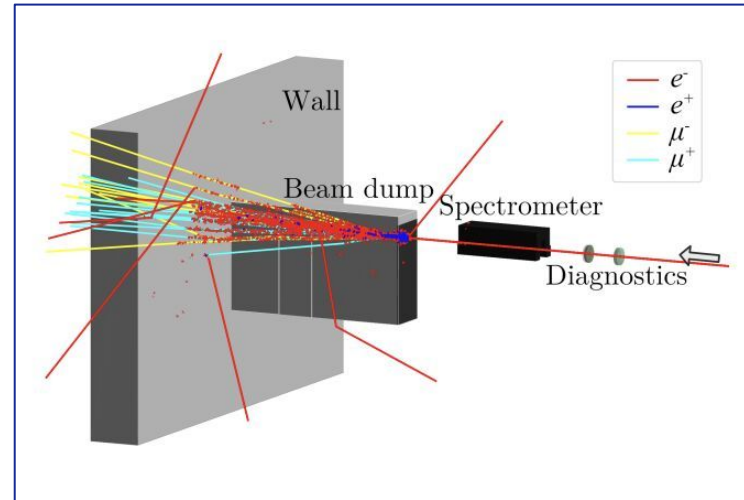
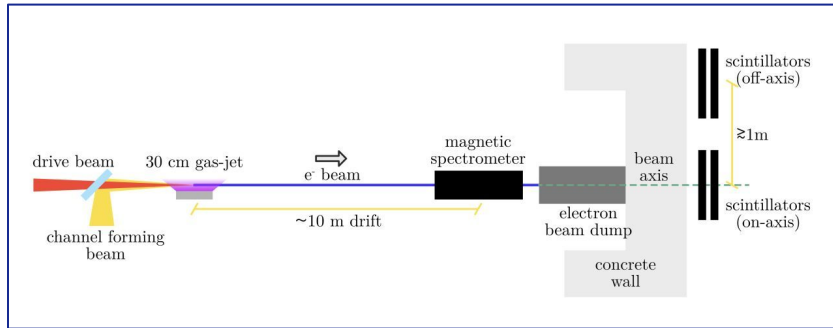

## Measurement of directional muon beams generated at the Berkeley Lab Laser Accelerator

Davide Terzani,<sup>1,\*</sup> Stanimir Kisiov,<sup>1</sup> Stephen Greenberg,<sup>1,2</sup> Luc Le Pottier,<sup>1,2</sup> Maria Mironova,<sup>1</sup> Alex Picksley,<sup>1</sup> Joshua Stackhouse,<sup>1,3</sup> Hai-En Tsai,<sup>1</sup> Raymond Li,<sup>1,3</sup> Ela Rockafellow,<sup>4</sup> Timon Heim,<sup>1</sup> Maurice Garcia-Sciveres,<sup>1</sup> Carlo Benedetti,<sup>1</sup> John Valentine,<sup>1</sup> Howard Milchberg,<sup>4</sup> Kei Nakamura,<sup>1</sup> Anthony J. Gonsalves,<sup>1</sup> Jeroen van Tilborg,<sup>1</sup> Carl B. Schroeder,<sup>1,3</sup> Eric Esarey,<sup>1</sup> and Cameron G. R. Geddes<sup>1</sup>

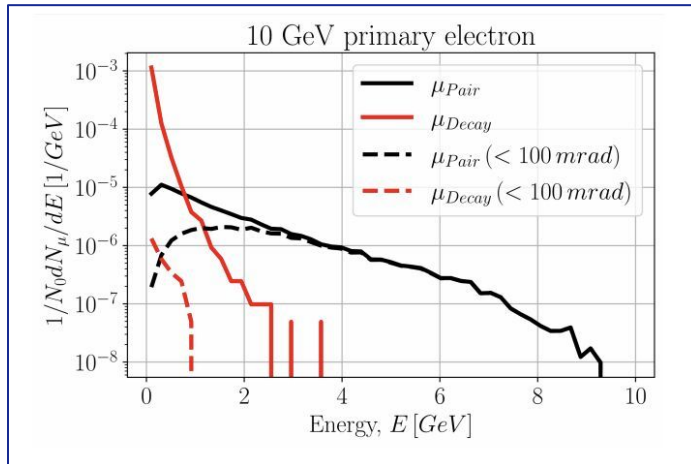

<https://arxiv.org/abs/2411.02321>

# Takeaway messages

- We have successfully implemented the technology so far
- We expect AI/ML implementation throughout the all data processing chain double our performance parameters
- Home-made DAQ gave a huge leap
- Continue with ASIC design for front-end readout: the energy consumption and waste heat the main reasons

Thank you!  
Questions?

Please, contact:  
[andi.hektor@gscan.eu](mailto:andi.hektor@gscan.eu)

 [gscan.eu](http://gscan.eu)

 [info@gscan.eu](mailto:info@gscan.eu)

 [linkedin.com/company/GScan](https://www.linkedin.com/company/GScan)